

Scaleable Solutions

WIRELESS
VERSATILE
DURABLE
ACCURATE

SCS^{plus} Digital Crane Scale

Designed for the most demanding industrial environment

Approved for commercial weighing

Superior expandability to meet changing user requirements

Vaa'at

Scales

Vekter

Balanças

电子秤

Vågar

ВЕСЫ

Waagen

कांटा

Básculas

Svari

Svarstykklés

الموازين

Vægte

Kaalud

Vogir

Balances

wagi

váhy



TRL10



Benefits

- Superior accuracy - reliability
- Legal for trade - direct invoicing
- Plug & Go - instant weighing on site
- Rugged construction - high durability
- USB & Radio data link - saves time



TAMTRON[®]
Scaleable Solutions

www.tamtron.fi

Optimal weighing solution to any environment



Modular wireless environment improves efficiency

Multi-use handheld unit Tamtron DR10 represents a new generation of radio remote controllers for Tamtron crane scales. This advanced handheld unit has a bright graphical display, simple menu based user interface and easy-to-use keyboard. With the DR10 the user can send commands to the scale, monitor scales' status and view the weighing information from a distance.



The DR10 handheld has a summing function and non-volatile data memory for up to 1800 weighing results with time and date label as well as an optional product code. The data can be transferred to PC conveniently via TRL10 radio modem with USB interface. Furthermore, DR10 can be linked to PC through USB cable.

TRL10 (Tamtron Radio Link) enables modular data transfer solutions based on the specific customer requirement and current operational environment. Several TRL10 units can be linked together enabling extended and customized data communication range.

All-around scale for many applications

The SCS^{plus} crane scale is meant for demanding industrial use and thus designed to be easy to use. The large display and remote control allows convenient use in all circumstances. Advanced movement compensation ensures accurate weighing even if the load is swinging.

Thanks to modular design of the scale, the SCS^{plus} can be operated in versatile weighing roles. The wide range of optional features and accessories enables to build optimal product package to any environment.

Technical data: DR10

Display:	64x128 pixels graphical LCD with white LED backlight
Charge level indication:	For scale and DR10
Operation time:	Up to 65 hours
Operational range:	200 m in the line of sight
Non-volatile memory:	1800 weighing records with time, date and material codes (option)
USB connection:	Data upload to PC via USB cable and charging
Radio frequency:	433.23Mhz - 434.35Mhz / 10 user selectable channels
Weight:	200 g (including batteries)
Operation temperature:	-20°C to +55°C

Technical data: Scale unit

- Accuracy ± 0,05 % of capacity
- Taring 100 % of capacity
- Load cell breaking strength 500 % of capacity
- Allowed peak load 200 % of capacity
- Five digit 50 mm LED display
- Gross/net function and zeroing
- Overload warning
- Automatic stand-by mode if unused for 10 minutes
- Real-time clock, date and time
- Automatic system diagnostics and zeroing in start-up
- Digital filter to assure superior stability with moving loads
- Operation time with fully charged battery over 100 hours
- Operation temperature range: -20°C...+50°C
- IP 65 cast aluminium case

Options

DR10 handheld

Foundry model:

The SCS^{plus} foundry model is especially suited for harsh and hot conditions

Shock protective steel frame

Wireless cross-beam

For weighing of longer objects
Scales can also be used separately

Verification certificate

OIML class III scale for commercial use

Battery exchange system

Radio transmission to PC

Optional external display also available

Lifting equipment for 20 - 50 ton capacities

Delivery includes

Standard infrared remote controller

Calibration certification

Charger

Up to 10 ton:

Safety hook, premium quality

Lifting ring, premium quality

From 20 ton onwards:

Shackles, premium quality

Dimensions

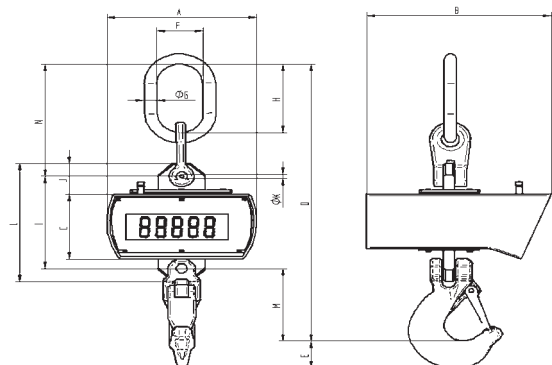

Capacity (kg)	Typical dimensions (mm)														Shackle	Weight (kg)	Step (kg)
	A	B	C	D	E	F	G	H	I	J	K	L	M	N			
3200	324	400	170	640	45	100	26	180	210	56	19,0	260	175	255		27	1
6300	324	400	170	699	52	110	32	200	225	83	23,5	280	195	279		34	1
10000	324	400	170	815,5	68	140	36	260	242	103	27,0	310	213,5	360		45	2
20000	324	400	170	646	82	-	-	-	290	130	52,0	400	-	-	178	32*	5
32000	324	400	170	704	103	-	-	-	310	146	59,0	440	-	-	197	40*	10
50000	324	400	170	873	130	-	-	-	340	170	72,0	500	-	-	266,5	48*	10

* weight without shackles

Sales by weight - fair business

The invoicing is based on the real amount loaded. The laws concerning commercial weighing require that the scale has to be approved for commercial use when sales is done based on weight. This kind of legal for trade scale can be recognised and the validity time seen from the stickers placed by local notified body. Moreover, a legal for trade scale is ideal also for control weighing due to its reliability.

Tamtron Group - reliable weighing equipment suppliers

Reliability is a result of know-how, quality work, continuity and resources. For Tamtron has been granted an ISO 9001:2000 quality certificate and rights to do initial verifications and service approvals. Tamtron Group and its wide network of qualified distributors all over the world take care of sales, approval and service quickly and economically.

Tamtron Group consists of Tamtron Oy, Tamtron Systems Oy, Tamtron Servers Oy and Tamtron Solutions Oy. Furthermore, Tamtron has subsidiaries in Sweden, Poland, Czech Republic, France and Estonia. Tamtron Group is specialised in deliveries of weighing equipment and information systems for demanding conditions. The Group has export to over 50 countries and over 22 000 deliveries worldwide.



TAMTRON OY

P.O. Box 15, (Vestonkatu 11)

FI-33561 Tampere, Finland

Tel. +358 3 3143 5000

Fax +358 3 3143 5050

Email: weighing@tamtron.fi

www.tamtron.fi

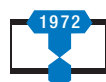

TAMTRON[®]
Scaleable Solutions

www.tamtron.fi